

ITEM NO.: GEVET EX30

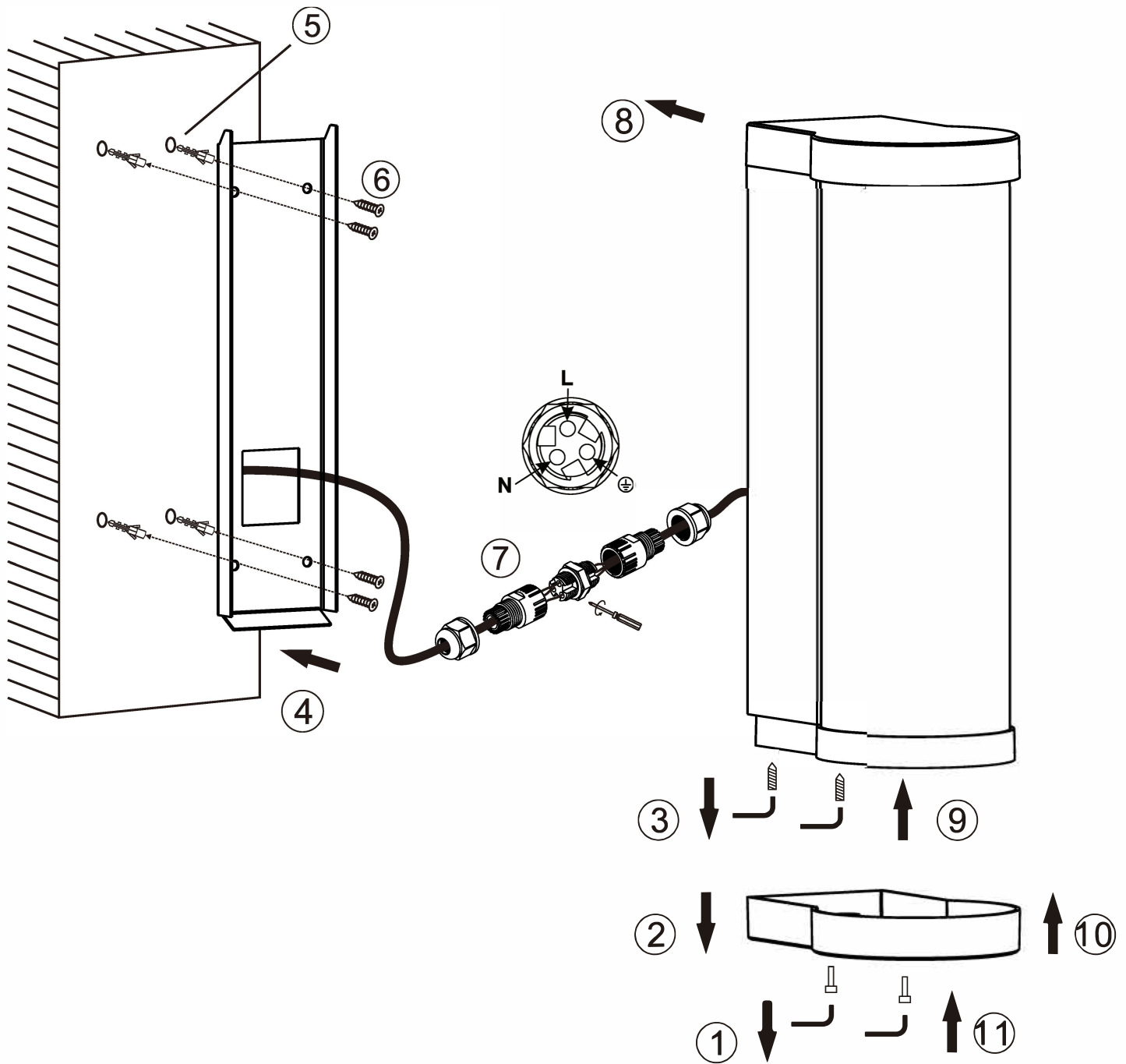

240V ~ 50Hz LED 12W 3000K
NON-DIM

IMPORTANT
Must be installed by
a qualified electrical
contractor.
Install in accordance
with AS/NZS3000